



Wireless communication, Wi-Fi (802.11 b/g/n)
Possible to access from anywhere in the world with cloud technology
Remote monitoring and testing with WELCO software
Single- or double-sided
Anodized aluminum case
Polycarbonate side cover and hanger
SMD LED application
Status display with green and red LEDs
Test switch
High-temperature Ni-Cd battery cells
Overcharge and deep discharge protection
White acrylic plate
Back lighting
Ceiling mounted, ceiling recessed or wall mounted
Optional - 110 VAC compatibility
Optional - Metal hanger, hook or steel wire
Optional - LiFePO4 or Ni-MH battery application

Please refer to "Pictogram Table" in Emergency Exit Luminaires Overview section of the catalogue for alternatives.



In accordance with EN 60598-1, EN 60598-2-22, EN 62034 standards.

TECHNICAL DATA

SUPPLY VOLTAGE :	230 VAC 50/60 Hz	SIGN DIMENSIONS :	163 x 329 mm
AMBIENT TEMPERATURE (ta) :	0 °C ... +40 °C	VIEWING DISTANCE :	26 m
RATED DURATION :	3 h	PROTECTION CLASS :	IP 20
BATTERY CHARGING TIME :	24 h	INSULATION CLASS :	I
BATTERY TYPE :	3,6 V Ni-Cd		

LED INDICATION FUNCTIONS

Permanent GREEN	Charge mode
Fast flashing GREEN (0,1s on - 0,1s off)	Function test
Slow flashing GREEN (1s on - 1s off)	Duration test
Permanent RED	Load failure
Slow flashing RED (1s on - 1s off)	Battery failure
Fast flashing RED (0,1s on - 0,1s off)	Charging failure
Double pulsing GREEN	Inhibit mode
Binary transmission of address via GREEN/RED	Addressing or identification
GREEN and RED off	Emergency mode

TEST SWITCH FUNCTIONS

Short press (<1s)	Starts the function test or terminate the all tests.
Long press (>5s)*	Starts the duration test.

* The battery must be 100% full before the duration test can be started.

PRODUCT CODE	RATED DURATION	OPERATING MODE*	LIGHT SOURCE	ROUTING MODE	TYPE OF MOUNTING
BYAL06-S/LED/WELCO	3 h	Maintained	12 x SMD LED	Double-sided (Lapin)	Surface Mounted - Plastic Hanger
BYAL06-S/LED/WELCO/SA	3 h	Maintained	12 x SMD LED	Double-sided (Lapin)	Recessed Mounted
BYAL07-S/LED/WELCO	3 h	Maintained	12 x SMD LED	Single-sided (Lipsos)	Surface Mounted - Plastic Hanger
BYAL07-S/LED/WELCO/SA	3 h	Maintained	12 x SMD LED	Single-sided (Lipsos)	Recessed Mounted

* Maintained: Lights on mains and stays alight in case of the mains failure.

MAINS DATA

PRODUCT CODE	RATED POWER (W)*	MAINS CURRENT (A)*	POWER FACTOR (PF)*	DIMENSIONS (mm)	WEIGHT (kg)	QTY in CARTON BOX
BYAL06-S/LED/WELCO	5,2	0,036	0,63	365 x 43 x 198	0,825	1
BYAL06-S/LED/WELCO/SA	5,2	0,036	0,63	425 x 43 x 216	0,955	1
BYAL07-S/LED/WELCO	5,2	0,036	0,63	365 x 43 x 198	0,970	1
BYAL07-S/LED/WELCO/SA	5,2	0,036	0,63	425 x 43 x 216	1,100	1

* Measured under 230 V mains.

WIRING DIAGRAM

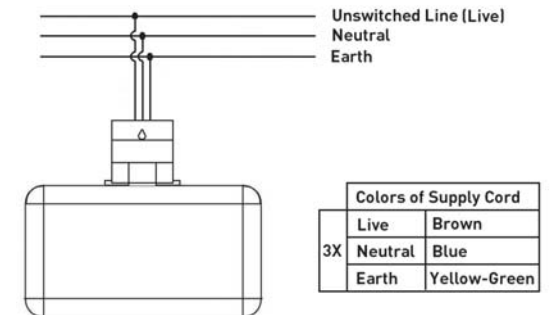

TECHNICAL DRAWING / SURFACE MOUNTED

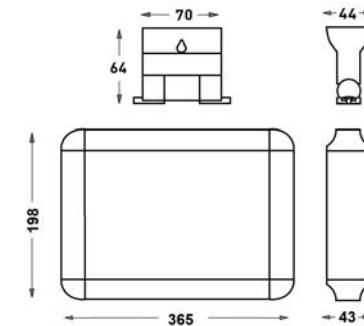

TECHNICAL DRAWING / RECESSED MOUNTED

